

loaf

# Squisharoo

Sofa Bed

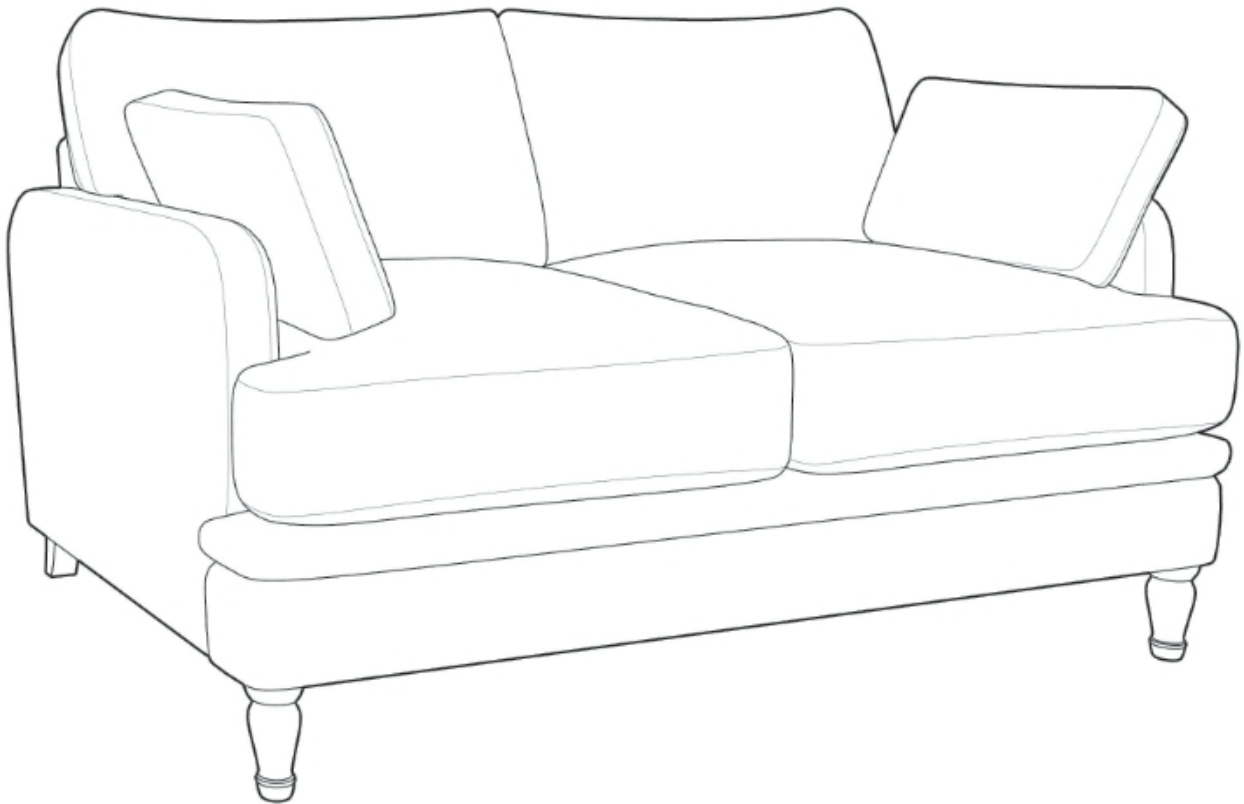

## Assembly Instructions

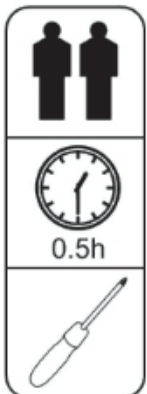

## - IMPORTANT -

READ THESE ASSEMBLY INSTRUCTIONS CAREFULLY - DO NOT SKIP ANY STEPS  
RETAIN THESE INSTRUCTIONS FOR FUTURE REFERENCE

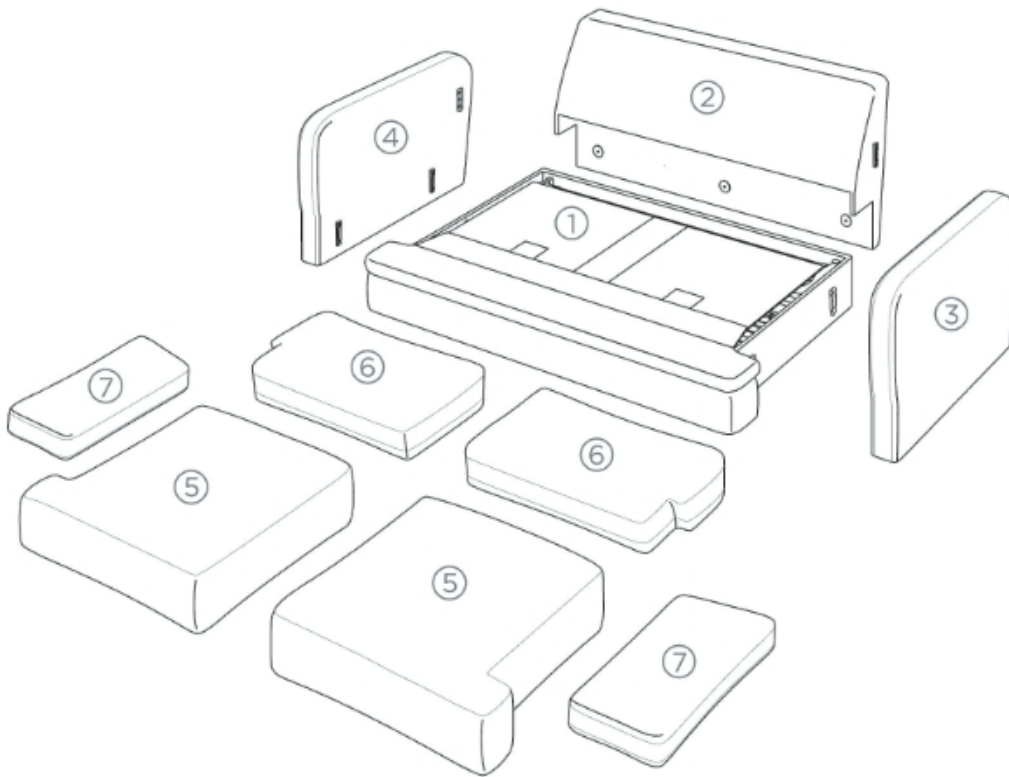

1		SEAT BOX	1
2		BACKREST	1
3		LEFT ARM	1
4		RIGHT ARM	1
5		SEAT CUSHION	2
6		BACK CUSHION	2
7		ARM CUSHION	2

A		FRONT LEGS	2
B		REAR LEGS	2
C		SUPPORT LEGS	2
D		CENTRAL SUPPORT LEG	1
E		WOOD SCREWS	2
F		BOLTS	3
G		FELT PADS	2

Carefully open all of the packaging and check that you have all of the parts and fittings listed above. Do not attempt to assemble or use the sofa if you are missing any parts. This may lead to damage of the sofa. Contact Loaf immediately to report any issues.

The sofa should be used on a levelled floor.

Always attach the provided felt pads to the bottom of each leg if you are placing the sofa on a hard surface such as wooden or stone floors.

Keep the sofa away from strong heat sources and direct sunlight as this can cause deterioration to the upholstery.

Periodically check that all fittings are securely in place. Re-adjust or re-tighten as necessary.

When positioning the sofa, do not drag. Always lift from the seat box. Once the sofa is in place, check that all of the central support legs are securely supporting the plinth. Re-adjust as necessary.

This product complies to BS12520

1

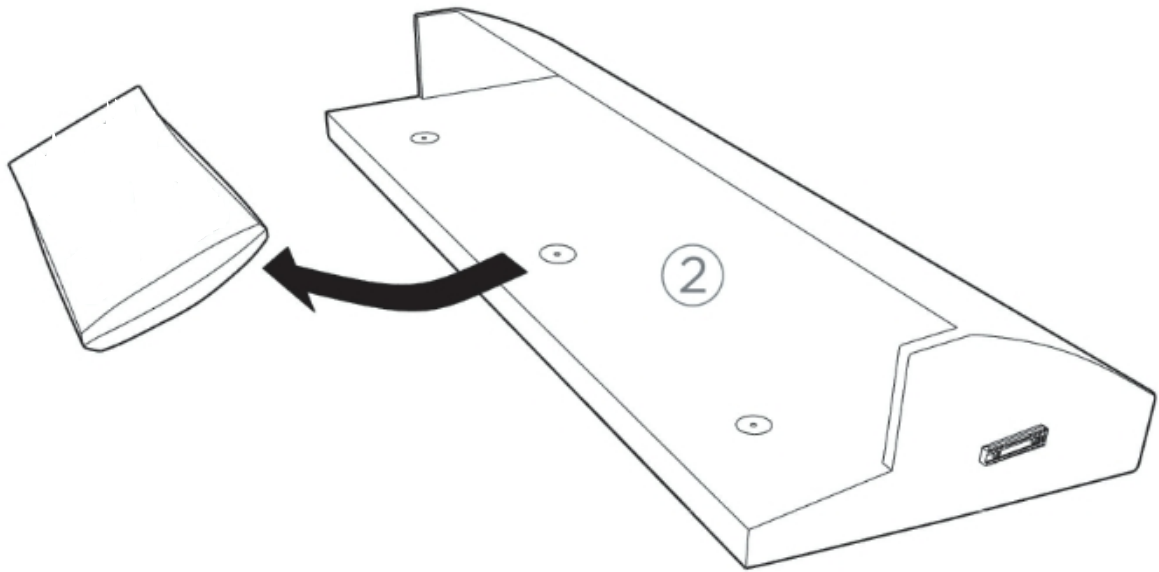

REMOVE THE POUCH CONTAINING THE LEGS, HARDWARE AND MUG FROM INSIDE OF THE BACKREST.

2

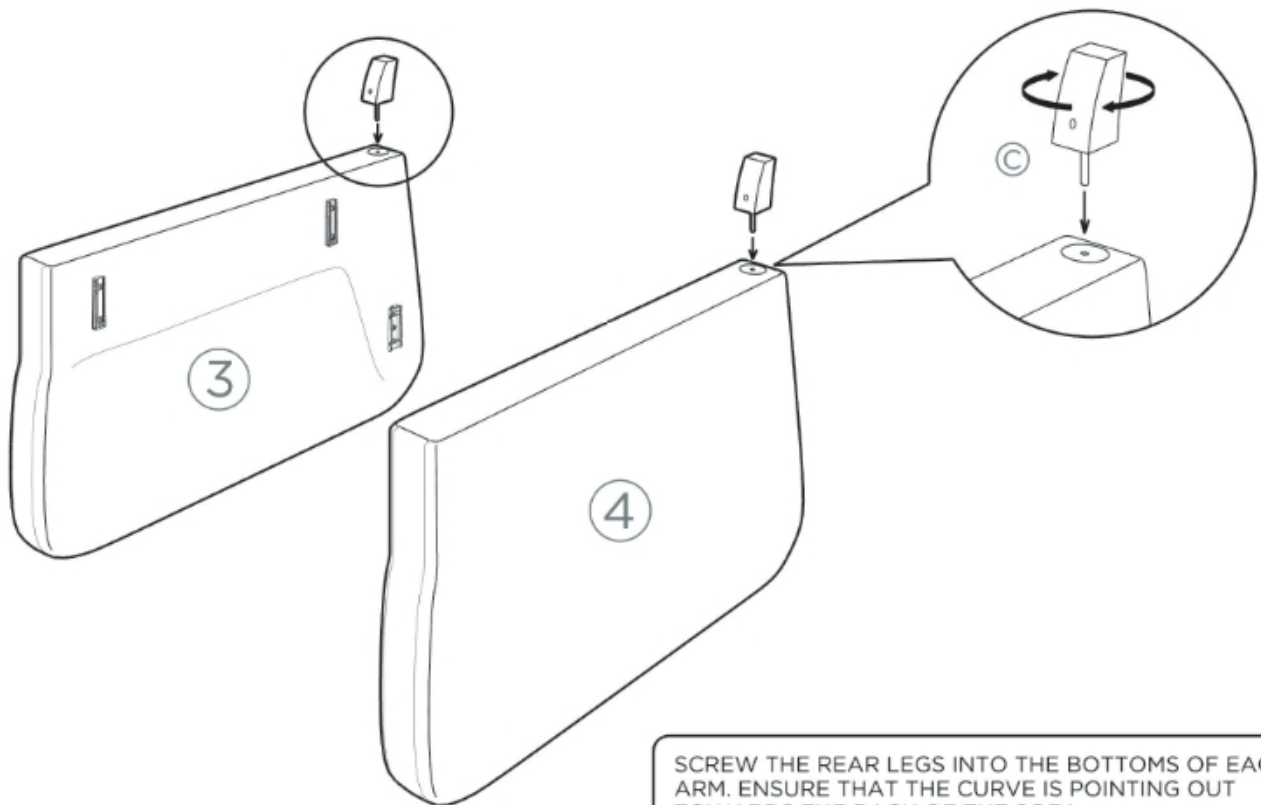

SCREW THE REAR LEGS INTO THE BOTTOMS OF EACH ARM. ENSURE THAT THE CURVE IS POINTING OUT TOWARDS THE BACK OF THE SOFA.

B		REAR LEGS	2
---	---	-----------	---

3

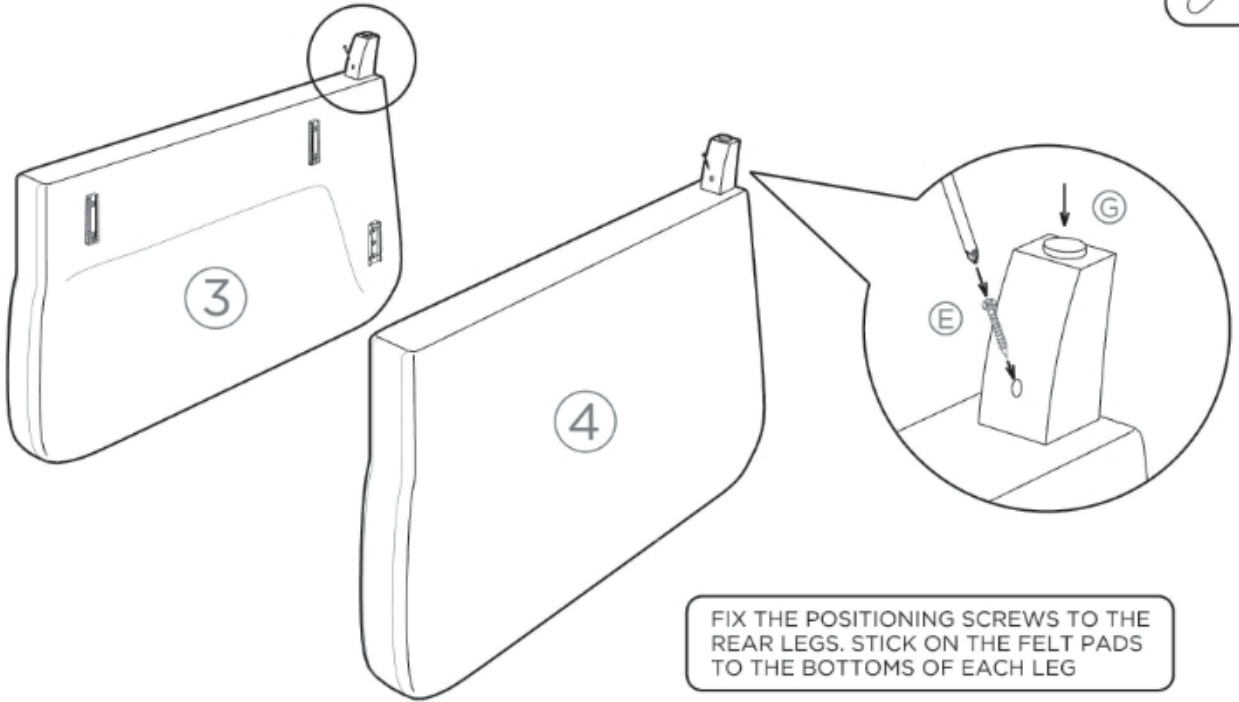

FIX THE POSITIONING SCREWS TO THE REAR LEGS. STICK ON THE FELT PADS TO THE BOTTOMS OF EACH LEG



4

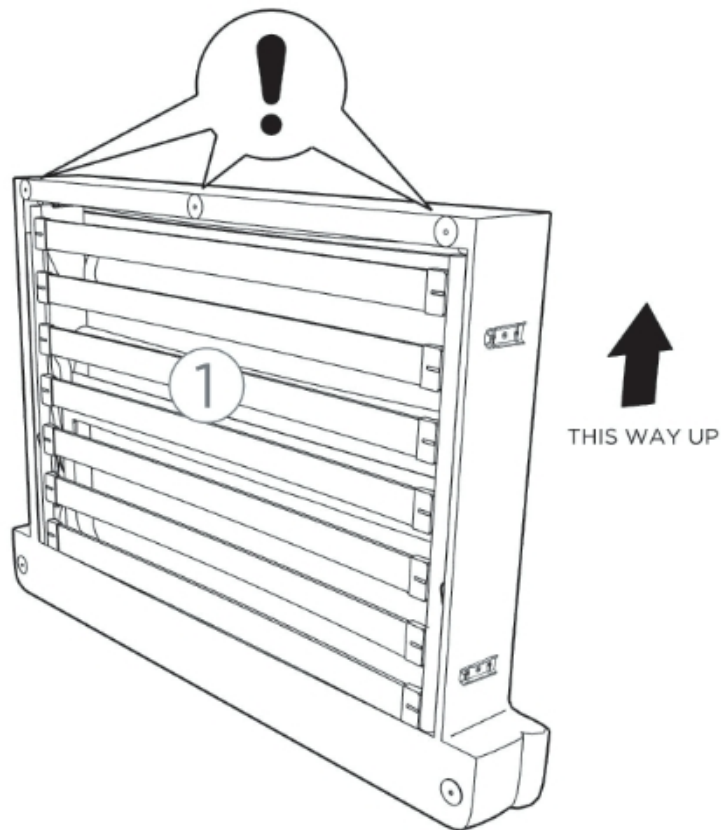

LIFT THE SEAT BOX INTO THE VERTICAL POSITION.  
**PLEASE NOTE:** THE CENTRAL SUPPORT LEG FIXING HOLES MUST BE ON THE TOP SIDE.

5

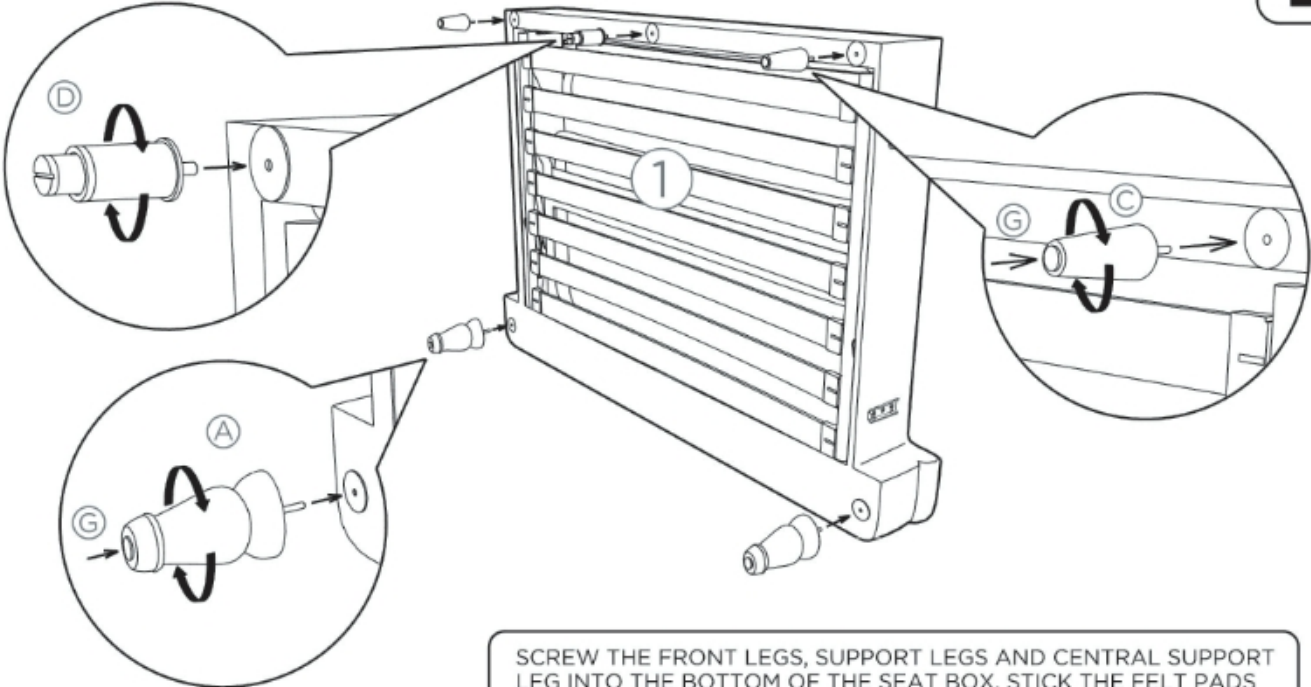

SCREW THE FRONT LEGS, SUPPORT LEGS AND CENTRAL SUPPORT LEG INTO THE BOTTOM OF THE SEAT BOX. STICK THE FELT PADS TO THE BOTTOM OF THE FRONT LEGS AND SUPPORT LEGS.

A		FRONT LEGS	2
---	--	------------	---

C		SUPPORT LEGS	2
---	--	--------------	---

D		CENTRAL SUPPORT LEG	1
---	--	---------------------	---

G		FELT PADS	4
---	--	-----------	---

6

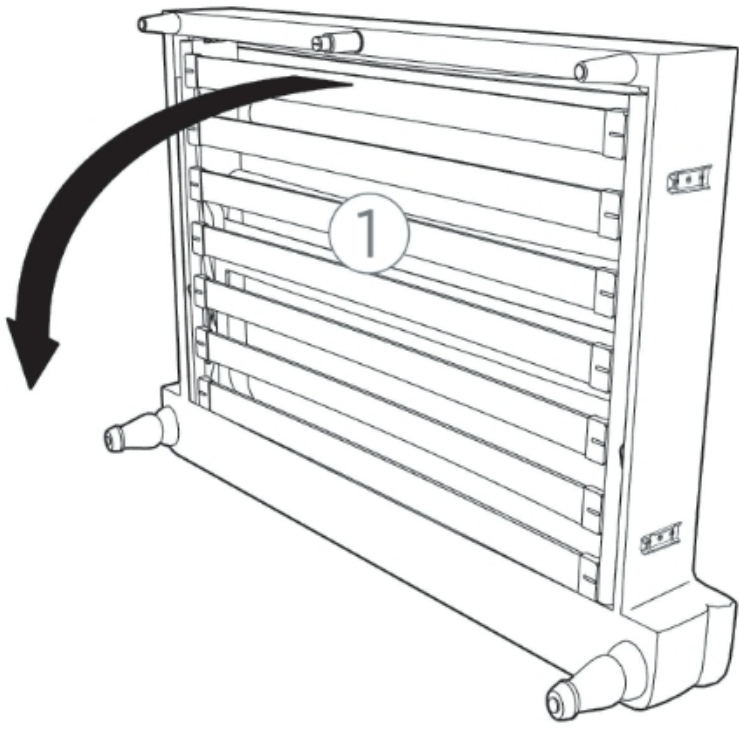

CAREFULLY LOWER THE SEAT BOX BACK TO THE HORIZONTAL POSITION.

7

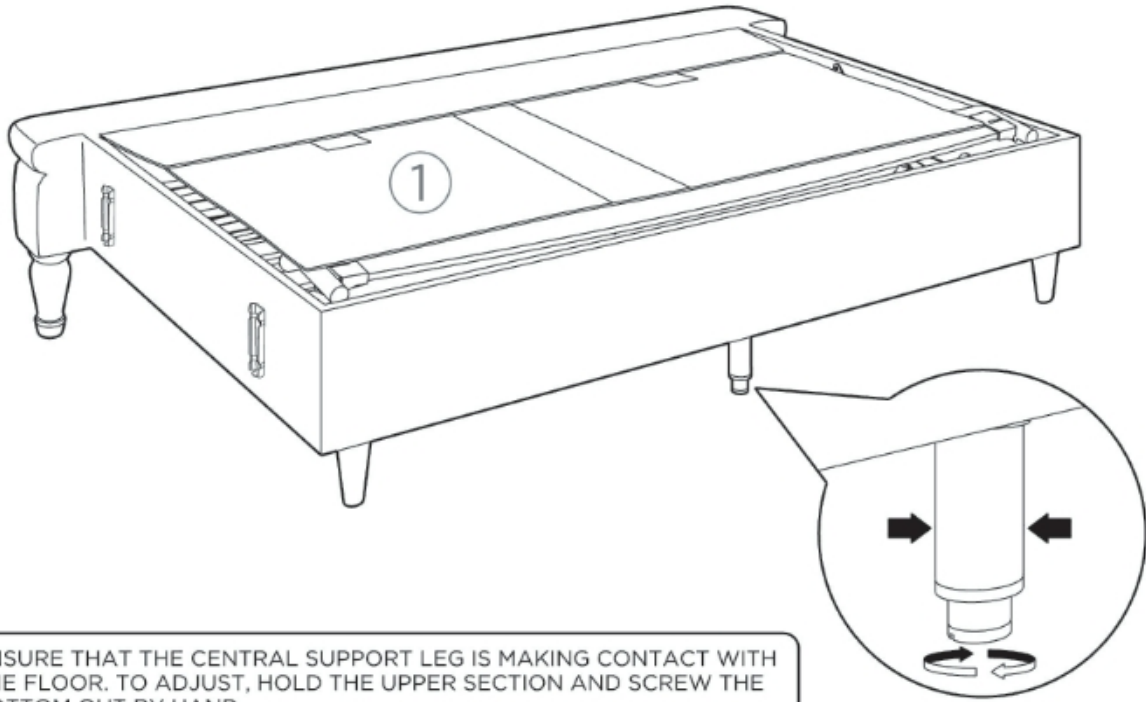

ENSURE THAT THE CENTRAL SUPPORT LEG IS MAKING CONTACT WITH THE FLOOR. TO ADJUST, HOLD THE UPPER SECTION AND SCREW THE BOTTOM OUT BY HAND.

D		CENTRAL SUPPORT LEG	1
---	--	---------------------	---

8

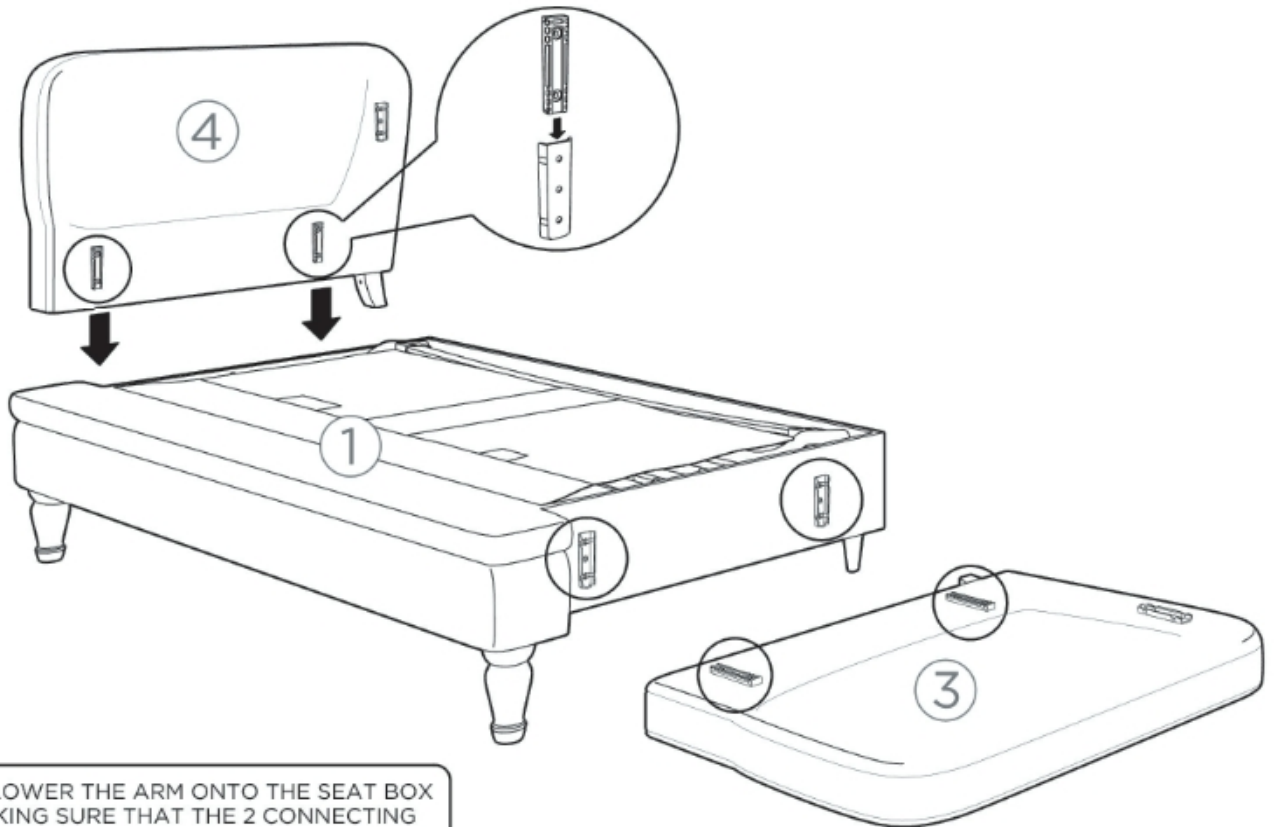

CAREFULLY LOWER THE ARM ONTO THE SEAT BOX WHILST MAKING SURE THAT THE 2 CONNECTING BRACKETS STAY ALIGNED. FIRMLY PUSH DOWN. REPEAT THE PROCESS ON THE OPPOSITE ARM.

9

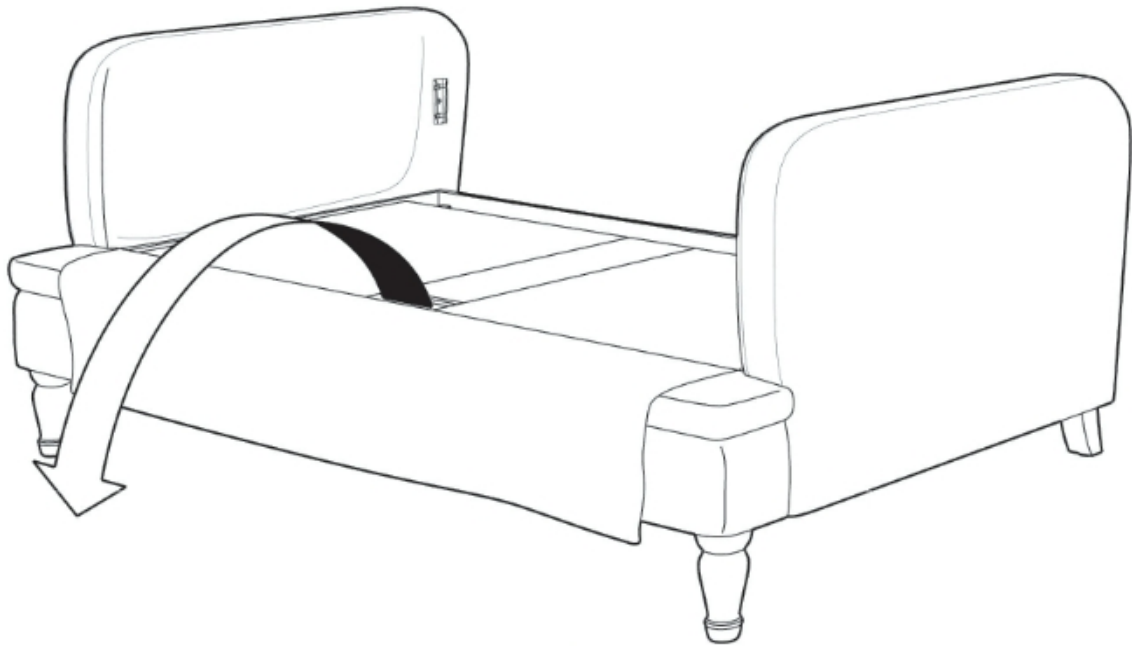

OPEN THE BED MECHANISM BY LIFTING UP THE TOP BAR.

10

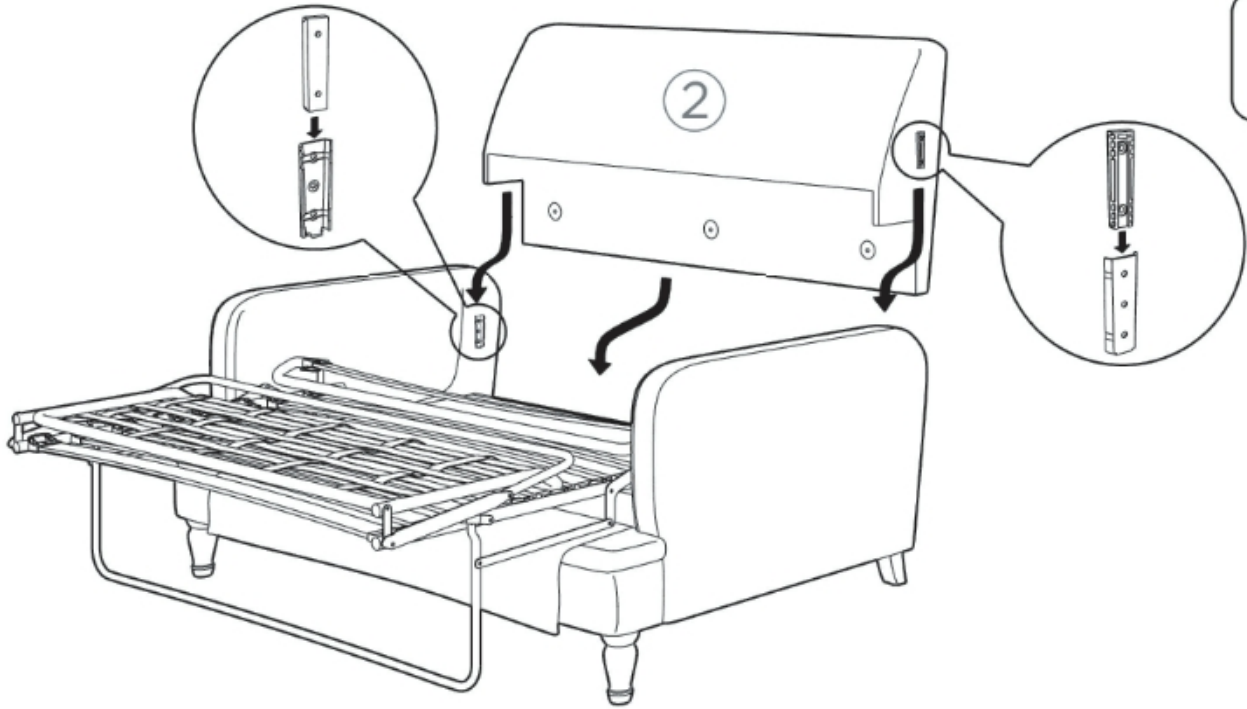

- WITH 2 PEOPLE -  
LIFT THE BACKREST AND PUSH INTO POSITION FROM THE REAR OF THE SOFA.  
ALIGN THE TWO SIDE CONNECTING BRACKETS AND FIRMLY PUSH DOWN.

11

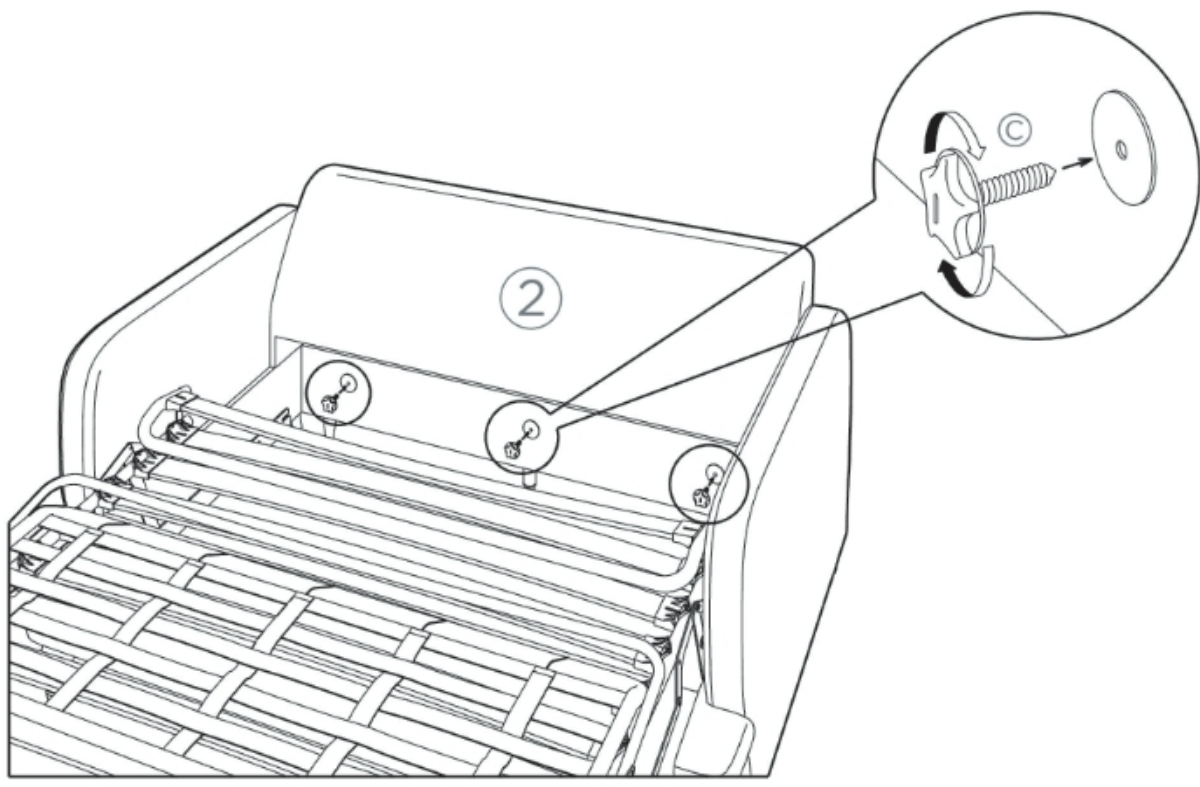

F		BOLTS	3
---	---	-------	---

SECURE THE BACKREST TO THE SEAT BOX USING THE PROVIDED BOLTS. CLOSE THE BED MECHANISM AFTER THIS STEP.

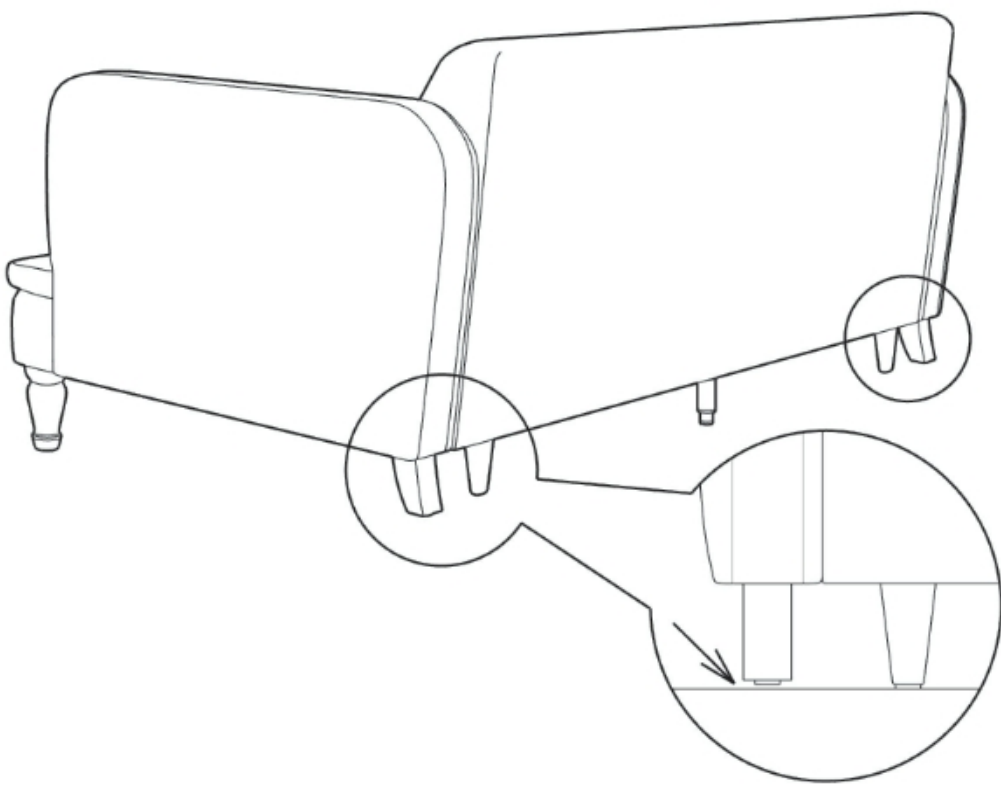

**PLEASE NOTE:** THE REAR LEGS THAT ARE ATTACHED TO THE ARMS MAY NOT MAKE CONTACT WITH THE FLOOR. DON'T BE ALARMED. THIS IS NORMAL. THE WEIGHT OF THE SOFA IS SUPPORTED BY THE SUPPORT AND CENTRAL SUPPORT LEGS.

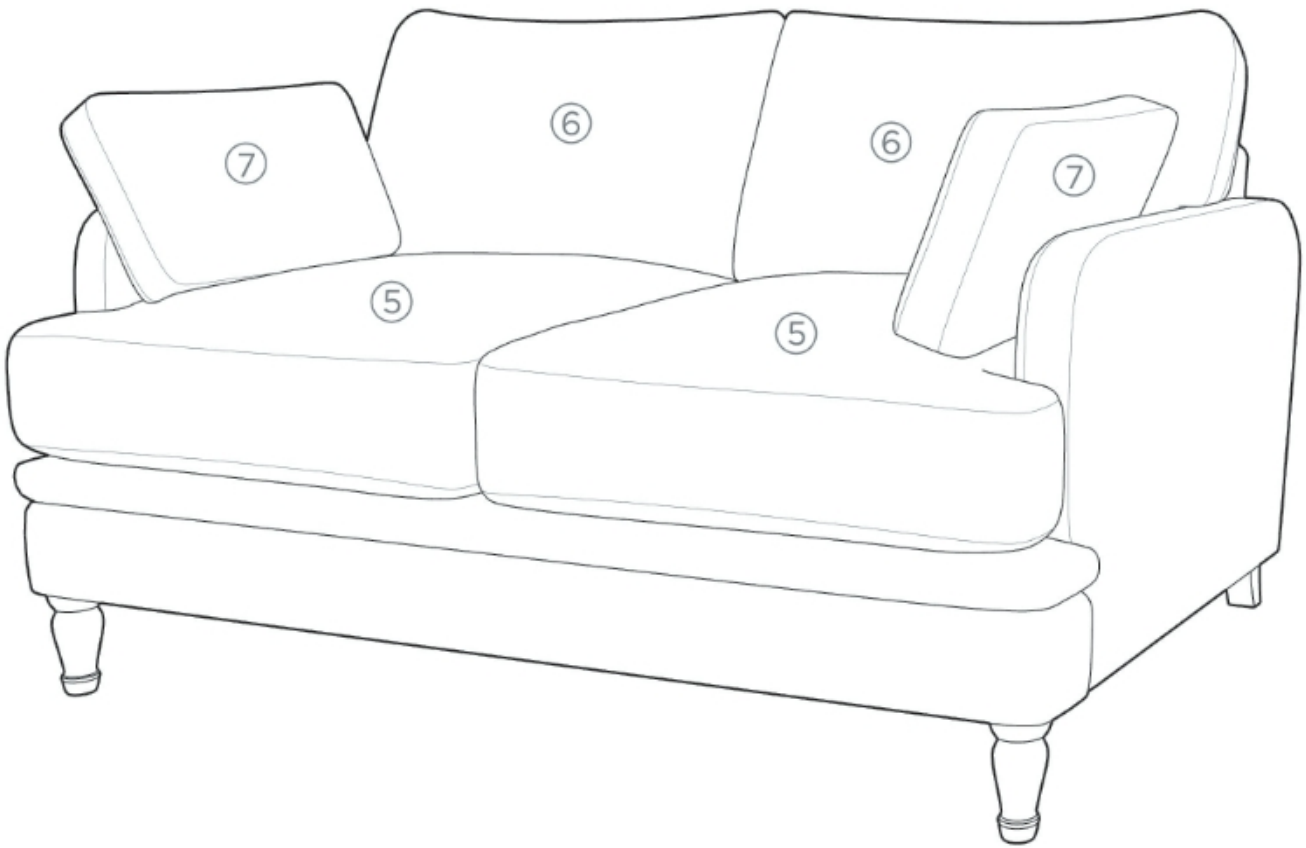

PLACE THE SEAT CUSHIONS ON FIRST THEN THE BACK CUSHIONS FOLLOWED BY THE ARM CUSHIONS.  
**TOP TIP!** IF YOU HAVE CHOSEN VELVET, YOU MAY NEED TO CAREFULLY SMOOTHEN OUT THE FABRIC IN ONE DIRECTION.