

loaf

# Brioche

Extra Large Sofa

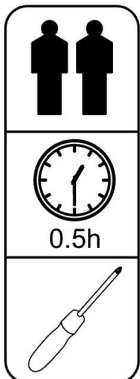

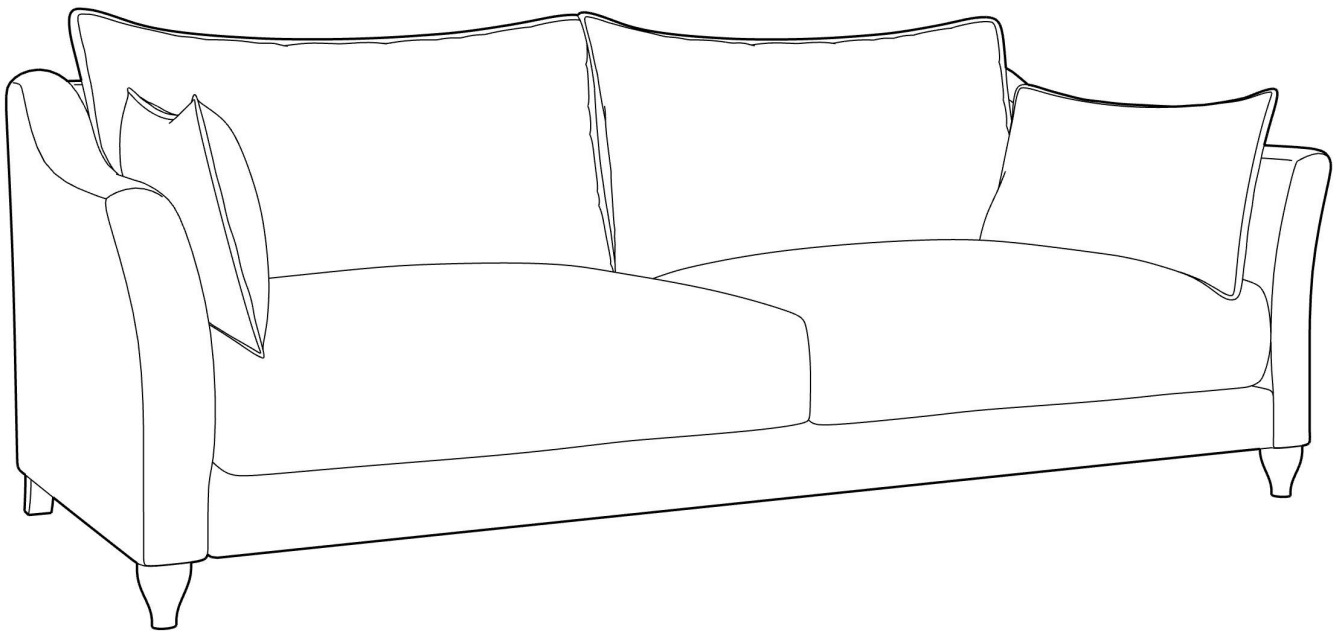



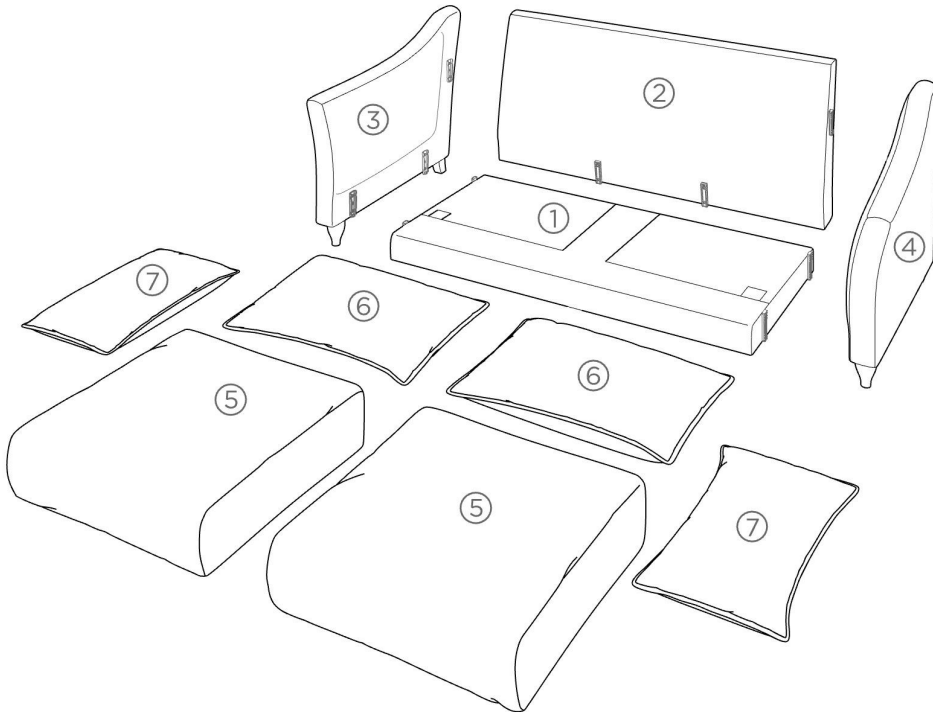

## Assembly Instructions

Loaf, Unit 8, 69 St Mark's Road, London, W10 6JG

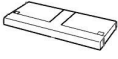
## - IMPORTANT -

READ THESE ASSEMBLY INSTRUCTIONS CAREFULLY - DO NOT SKIP ANY STEPS  
RETAIN THESE INSTRUCTIONS FOR FUTURE REFERENCE



1		SEAT BOX	1
2		BACKREST	1
3		LEFT ARM	1
4		RIGHT ARM	1
5		SEAT CUSHION	2
6		BACK CUSHION	2
7		ARM CUSHIONS	2

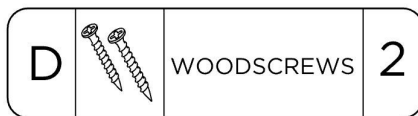

Carefully open all of the packaging and check that you have all of the parts and fittings listed above. Do not attempt to assemble or use the sofa if you are missing any parts. This may lead to damage of the sofa. Contact Loaf immediately to report any issues.

The sofa should be used on a levelled floor.

Always attach the provided felt pads to the bottom of each leg if you are placing the sofa on a hard surface such as a wooden or stone floor.

Keep the sofa away from strong heat sources and direct sunlight as this can cause damage to the upholstery.

Periodically check that all fittings are securely in place. Re-adjust or re-tighten as necessary.

When positioning the sofa, do not drag. Always lift from the armrests. Once the sofa is in place, check that all central support legs are securely supporting the plinth. Re-adjust as necessary.

This product complies to BS12520.

1

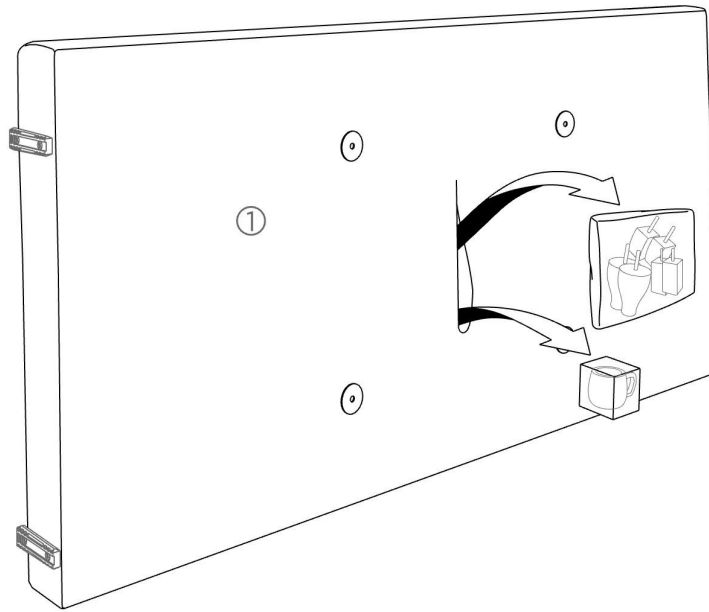

UNZIP THE BOTTOM COVERING AND REMOVE THE LEGS AND MUG FROM THE SEAT BOX

2

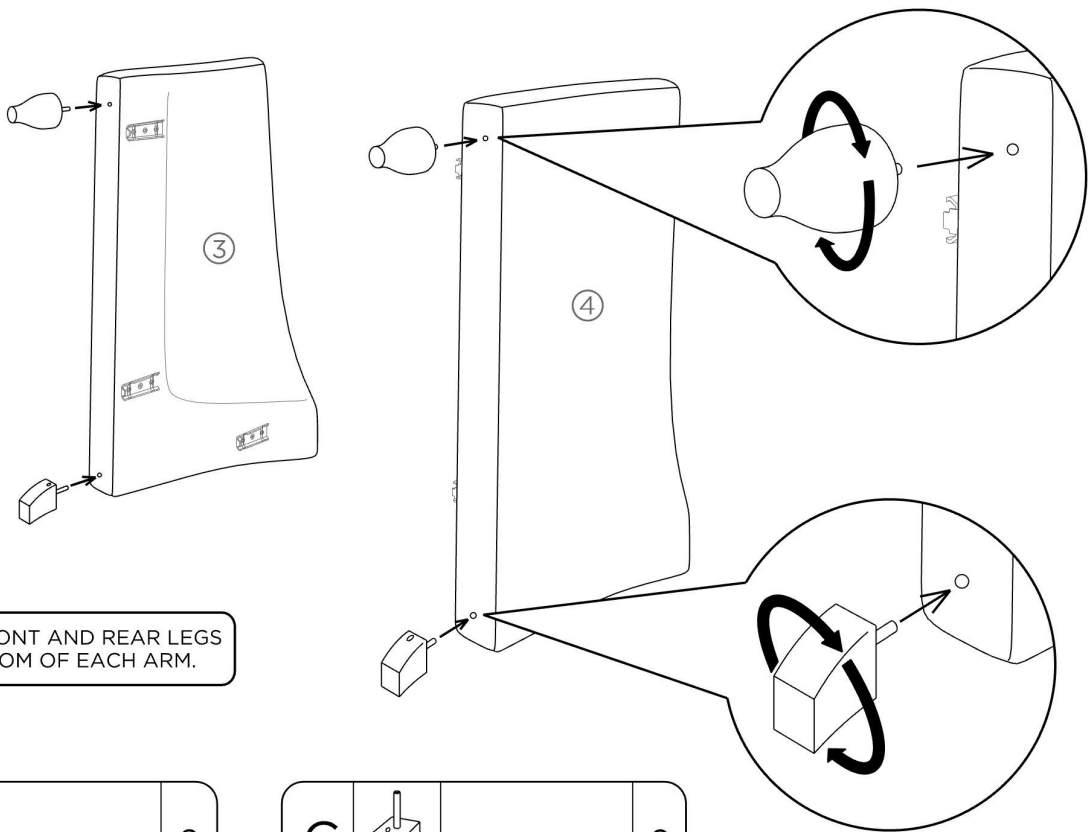

SCREW THE FRONT AND REAR LEGS INTO THE BOTTOM OF EACH ARM.

A		FRONT LEGS	2
---	---	------------	---

C		REAR LEGS	2
---	---	-----------	---

3

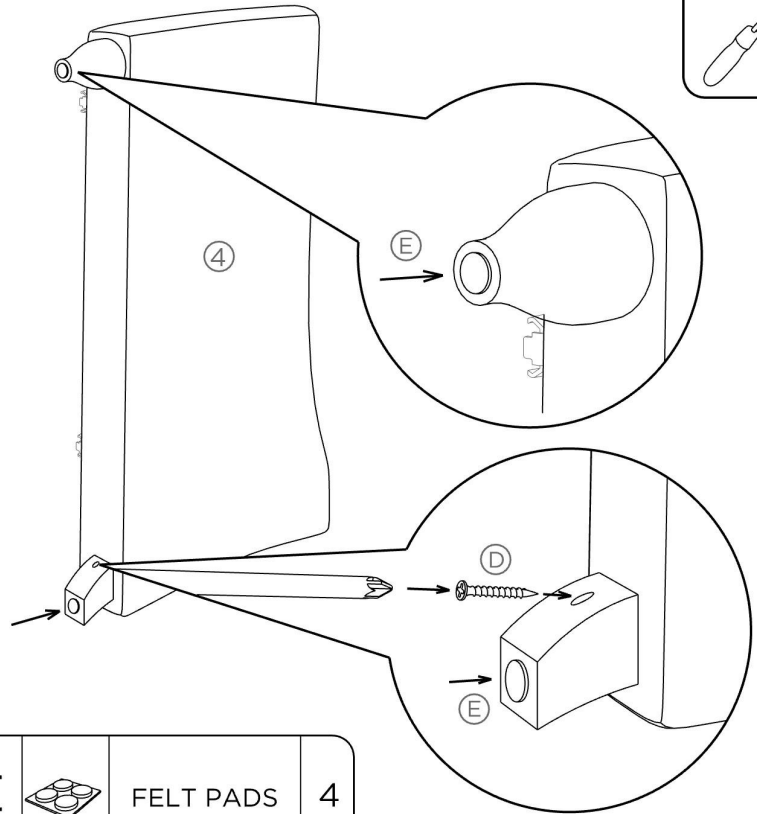
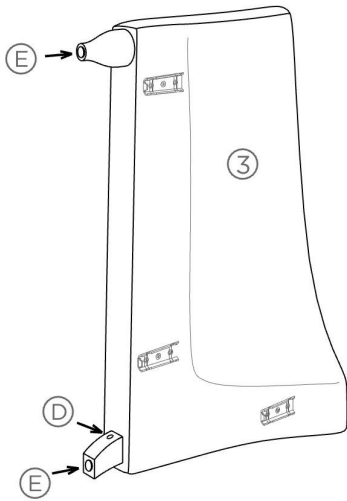

FIX THE POSITIONING SCREWS TO THE REAR LEGS THEN STICK THE FELT PADS TO THE BOTTOM OF EACH LEG.

D		WOODSCREWS	2
---	--	------------	---

E		FELT PADS	4
---	--	-----------	---

4

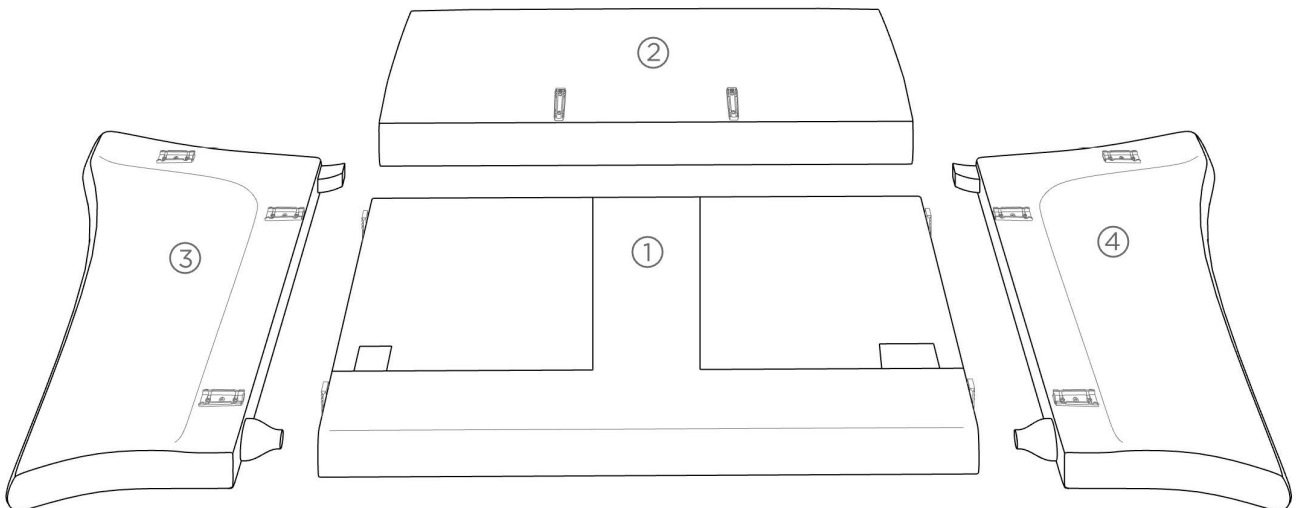

LAY OUT THE SEAT BOX, BACKREST AND ARMS READY FOR ASSEMBLY

5

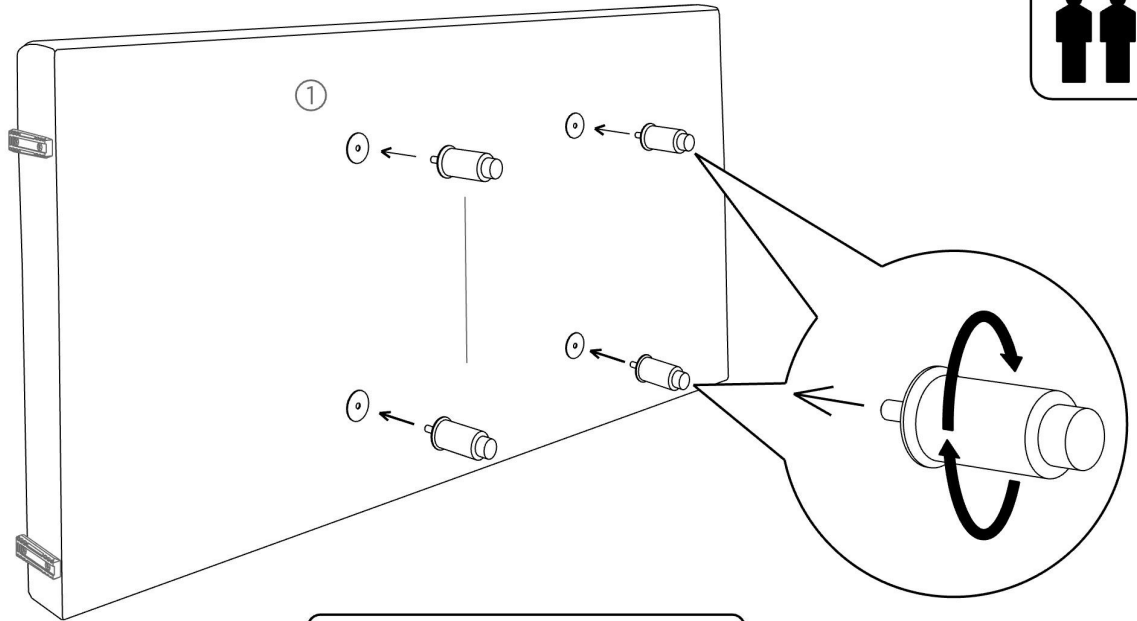

SCREW THE CENTRAL SUPPORT LEGS INTO THE BOTTOM OF THE SEAT BOX.

B		CENTRAL SUPPORT LEGS	4
---	--	----------------------	---

6

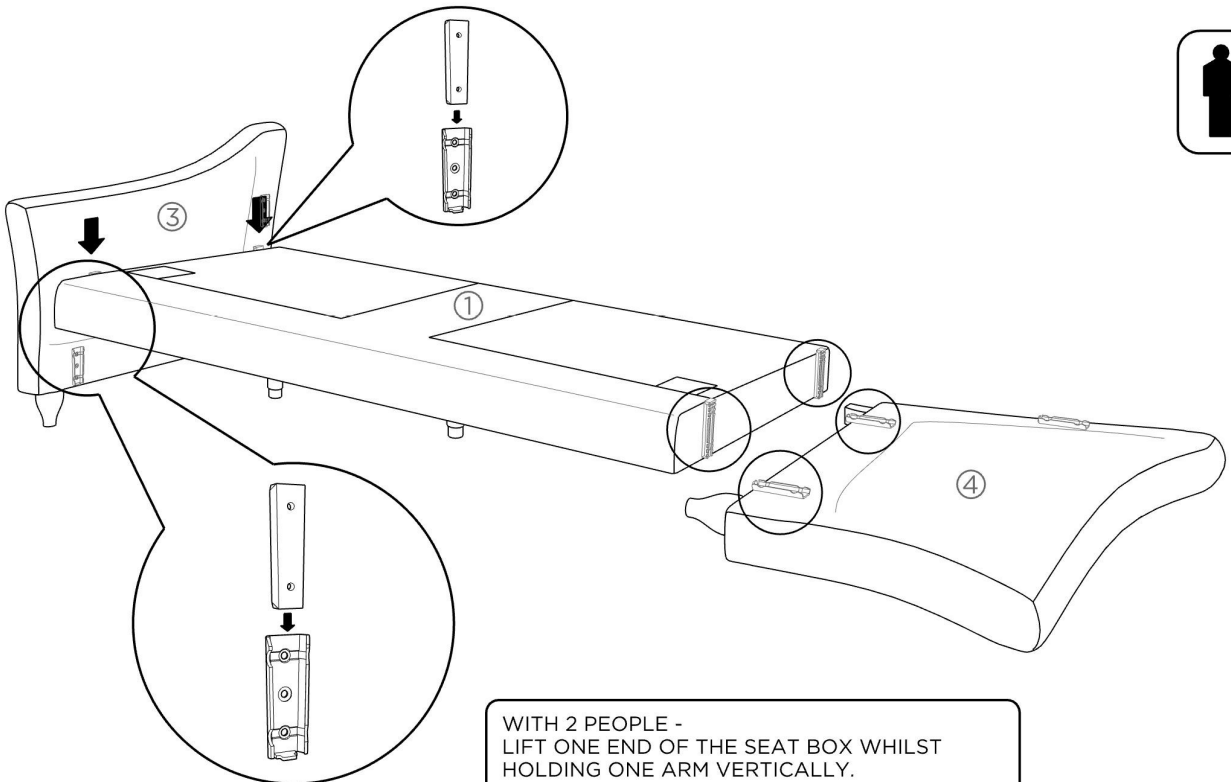

WITH 2 PEOPLE - LIFT ONE END OF THE SEAT BOX WHILST HOLDING ONE ARM VERTICALLY. CAREFULLY ALIGN EACH CONNECTING BRACKET AND FIRMLY PUSH DOWN. REPEAT THE PROCESS ON THE OPPOSITE ARM.

7

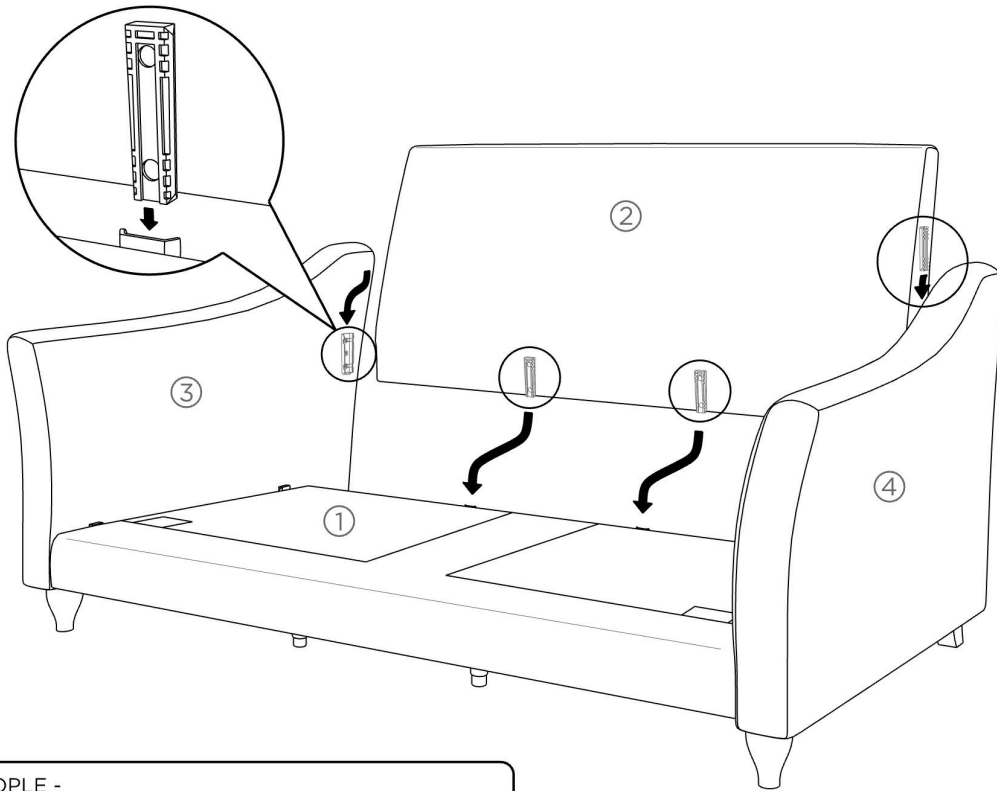

WITH 2 PEOPLE -  
LIFT THE BACKREST AND PUSH INTO POSITION FROM THE REAR OF THE SOFA. ALIGN THE TWO CENTRE BRACKETS FIRST THEN ALIGN THE SIDE BRACKETS WHILST PULLING THE ARMS IN, THEN PUSH DOWN FIRMLY.

8

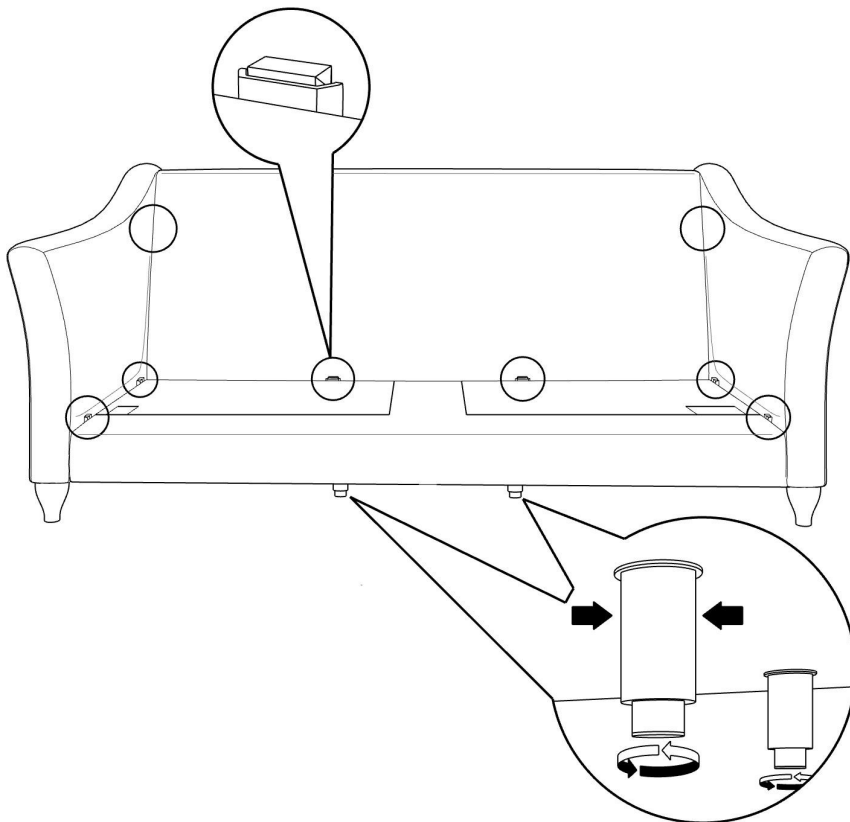

IMPORTANT: ENSURE THAT THE CENTRAL SUPPORT LEGS ARE FIRMLY RESTING ON THE FLOOR. TO ADJUST, HOLD THE UPPER SECTION IN PLACE AND TURN THE BOTTOM SECTION IN OR OUT. CAREFULLY CHECK THAT ALL SIX BRACKETS ARE FULLY PUSHED IN.

9

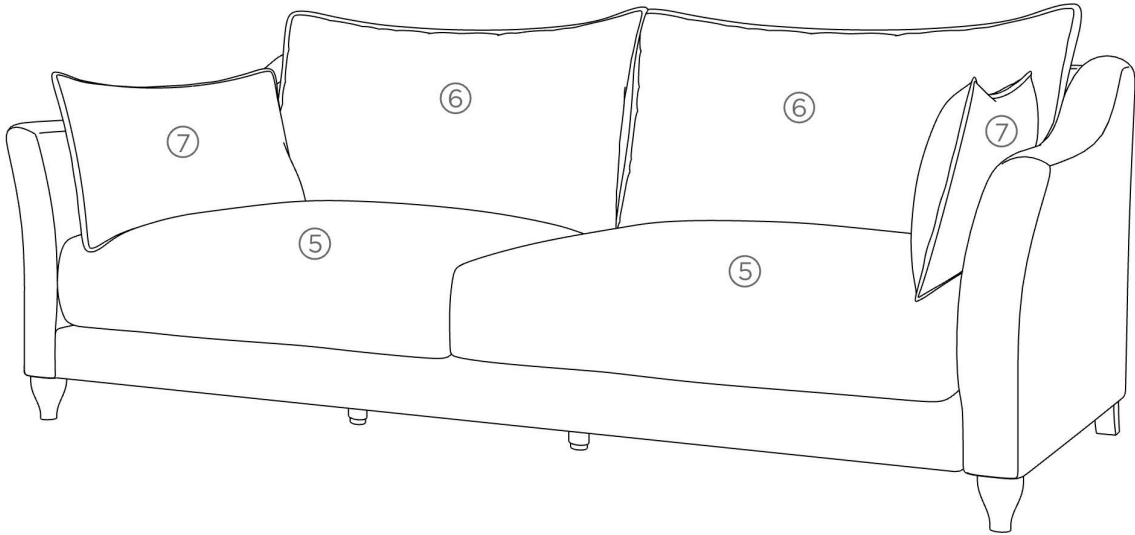

PLACE THE SEAT CUSHIONS ON FIRST THEN THE BACK CUSHIONS FOLLOWED BY THE ARM CUSHIONS.  
TOP TIP! IF YOU HAVE CHOSEN VELVET YOU MAY NEED TO SMOOTH THE FABRIC IN ONE DIRECTION.

# Sofa Disassembly Instructions

